

DESIGNED FOR USE WITH .085 S.R.	
CABLE ENTRY DIAMETER MINIMUM	
CLAMP NUT	.089
SLEEVE	.064
CONTACT	.021

REVISIONS			
REV	DESCRIPTION	DATE	APPROVED
01 ₀	RELEASED	11-3-97	KYLE

RECOMMENDED
MOUNTING HOLE

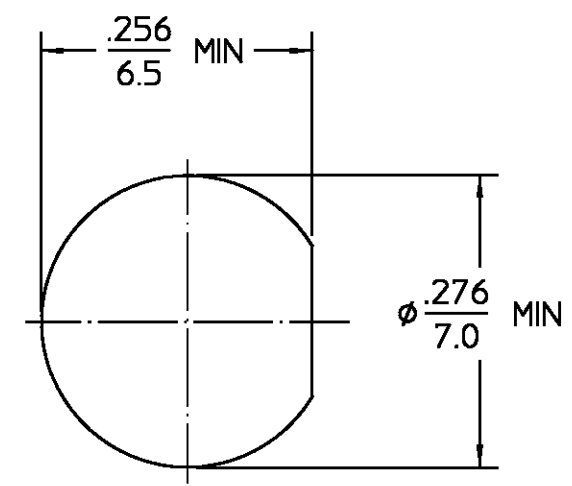

SLEEVE	STAINLESS STEEL PER ASTM-A484 AND ASTM- A582, TYPE 303	GOLD PLATE PER MIL-G-45204
HOUSING CLAMP NUT MOUNTING NUT BUSHING	STAINLESS STEEL PER ASTM-A484 AND ASTM- A582, TYPE 303	PASSIVATE PER QQ-P-35
DIELECTRIC	PTFE FLUOROCARBON PER ASTM-D-1457	N/A
CENTER CONTACT	BERYLLIUM COPPER PER ASTM-B-196 OR ASTM-B-197, ALLOY C17300, CONDITION H	GOLD PLATE PER MIL-G-45204
LOCKWASHER	BERYLLIUM COPPER PER ASTM-B-196, ALLOY C17300, CONDITION H	GOLD PLATE PER MIL-G-45204
CAP	VINYL PLASTIC	N/A
COMPONENT	MATERIAL	FINISH

UNLESS OTHERWISE SPECIFIED DIMENSIONS ARE IN INCHES	DRAWN BY KYLE LE	DATE 11-3-97	AMP Incorporated 140 Fourth Avenue Waltham, MA 02451-7599	
	CHECKED BY	APPD BY		
FRAC. ± 1/64	DEC. ± .005	ANGLES ± 1°	TITLE "OS-50" BULKHEAD FEEDTHRU CABLE JACK CLAMP ATTACHMENT	
These drawings and speci- fications are the property of M/A COM Interconnect Div. and shall not be reproduced or copied or used in whole or in part as the basis for the manufacture or sale of item(s) without written permission.			USE ASSY PROCEDURE	NO. A.P. 408-04616 (85-002)
			SIZE B	CODE IDENT NO. 26805
			SCALE 6:1	SHEET 1 OF 1

NOTES:
1. CAPTURED CENTER CONTACT

.XXX = in
XX.X = mm (REF)

DESIGN CONTROL REQUIRED

CUSTOMER DRAWING

AMP PART # 1083600-1
SHEET 1 OF 1 REV A